

NOZZLE SCHEDULE

NO. MARK	SIZE	FLANGE		PIPE			Q'TY	DESIGNATION
		TYPE	RATING	SCH.	MATERIAL	LENG.		
N1	1S(15A)	SANITARY	-	-	STS316L	-	1	GAS INLET
N2	1S(15A)	SANITARY	-	-	STS316L	-	1	GAS OULET
N3	1/2"(15A)	SOCKET	-	-	STS304	-	1	SAFTY VALVE
N4	1/2"(15A)	SOCKET	-	-	STS304	-	1	TEM. SENSOR

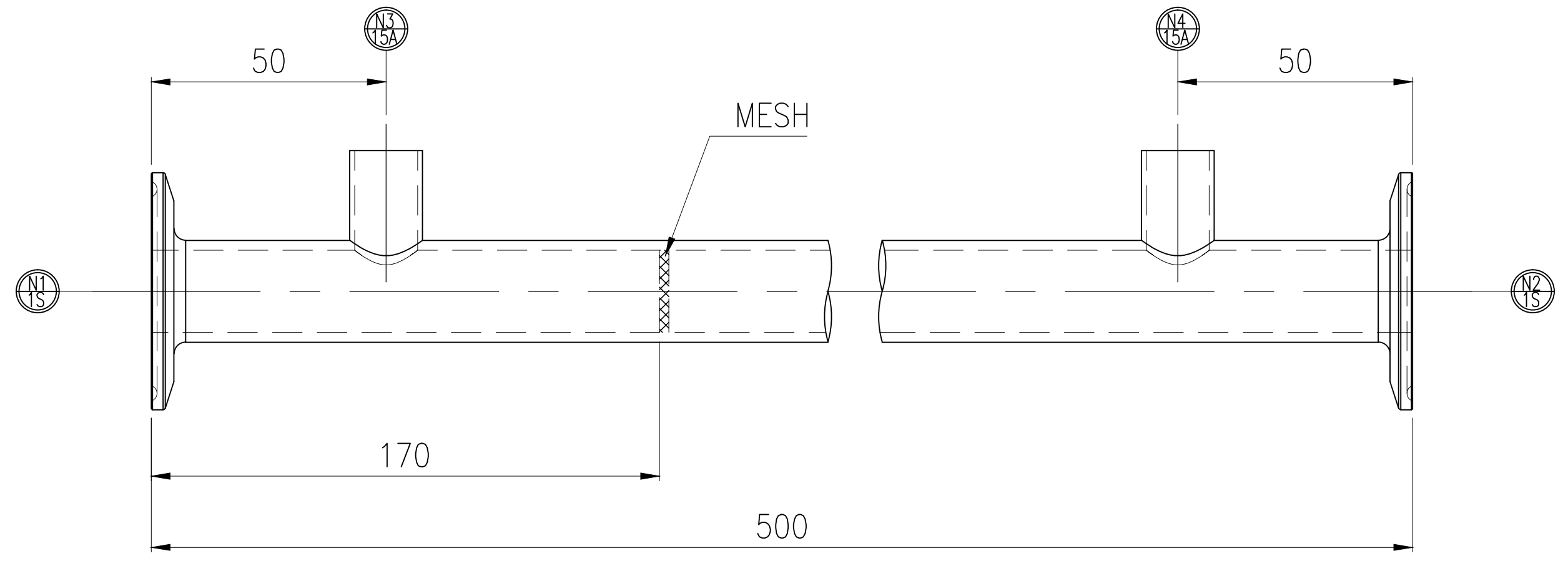

1	MAIN REACTOR	STS316L	15A	1	POLISHING
PART	DESCRIPTION	MATERIAL	SIZE	Q'TY	REMARK
3					
2					
1					
NO	Rev. DATE.	DESCRIPTION			
CUSTOMER		한국화학연구원		DRAWING	DESIGNED
				I.H KIM	H.G KIM
TITLE/MODEL		메인 반응기		DATE	18. 11. 06
				SCALE	1 / 1
Anytech (주)애니텍				DWG NO.	
				-	